

NOTES:
 1 - LEAD/BODY BASE MATERIAL IS KOVAR.
 2 - LEAD/BODY FINISH IS 50U" GOLD/NI.
 3 - MEASURED WITHIN .05" OF BODY.

DASH	DESCRIPTION
NONE	PER DRAWING
A	CUSTOMER SPECIFIED PLATING

C

B

A

C

B

A

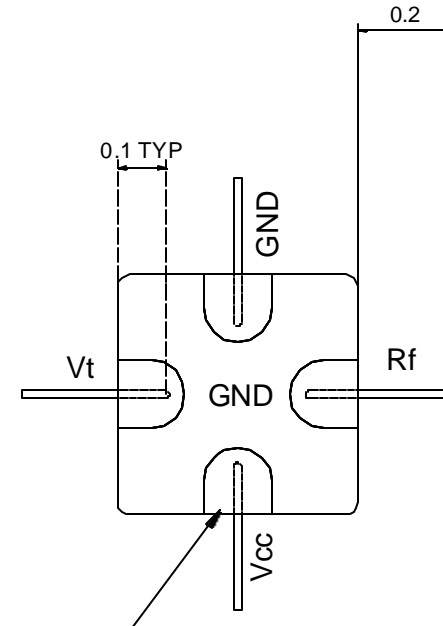
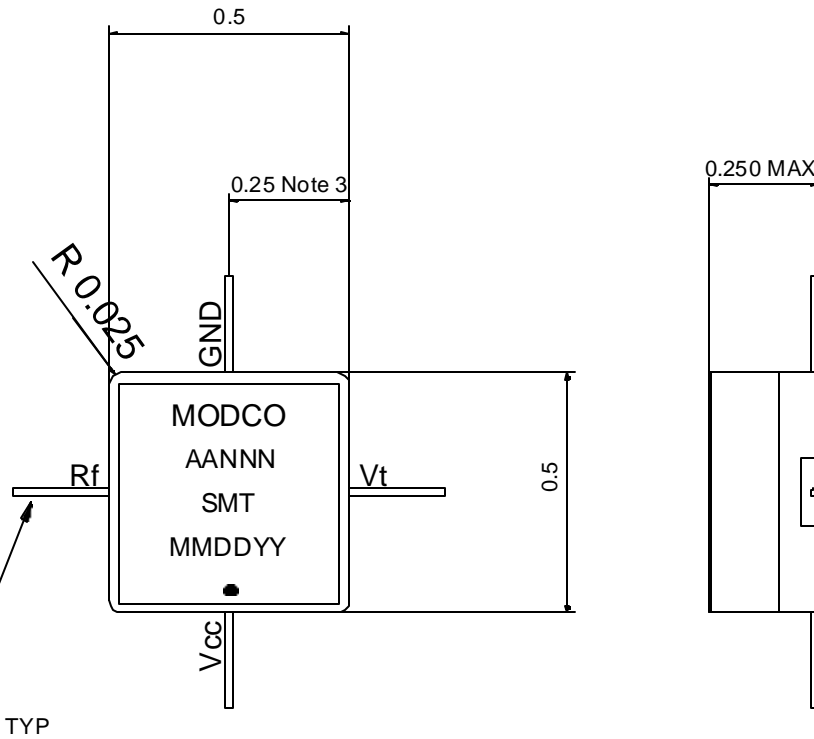

GLASS FRIT SEAL

Part labeling

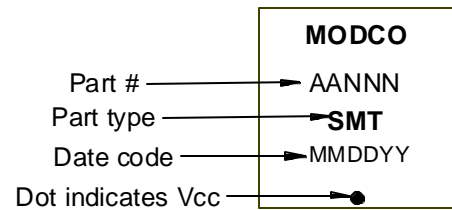

Part labeling
 Part number: AA=Alpha pre-fix, product family or custom part designator.
 NNN=Numeric 3 to 4 digit specific part number
 Part type: 2 to 4 alpha part type designator
 Date code: MM=month, DD=day, YY=year
 Label material is high temp. polyester film, opaque white, with black marking.

F	Change thickness from .225 to .250MAX.
E	Add I/O designators to bottom view.
D	New style package.
C	Added dash table.
B	UPDATED ADDRESS FROM 808 TO 806
A	RELEASED ON NEW FORMAT

Revision History

DATE:	10/12/04	MODCO, INC. 806 PACKER WAY SPARKS NV 89431 TEL: (775) 331-2442 FAX: (775) 331-6266
BY:	D. JOHNSON	
CHECKED:	F. Landrey	
REV:	F	
DRAWING #:	SMT SPEC NEW.MKD	TITLE: SMT FINISHED PACKAGE SPECIFICATION

1

2

3

4