

1

2

3

4

TOP VIEW

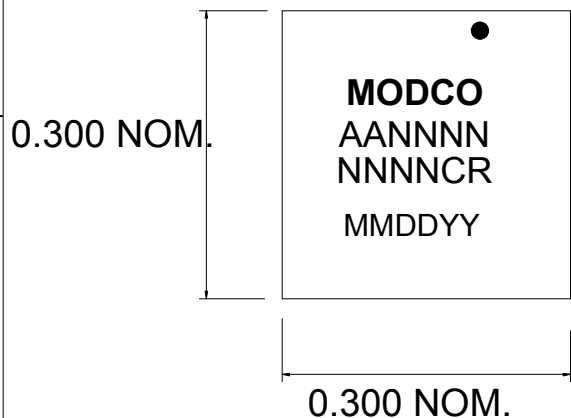

SIDE VIEW

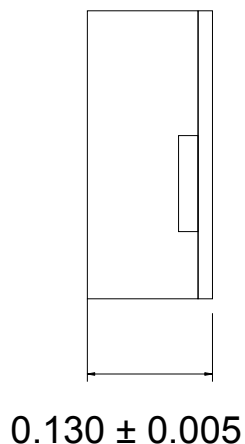

BOTTOM VIEW

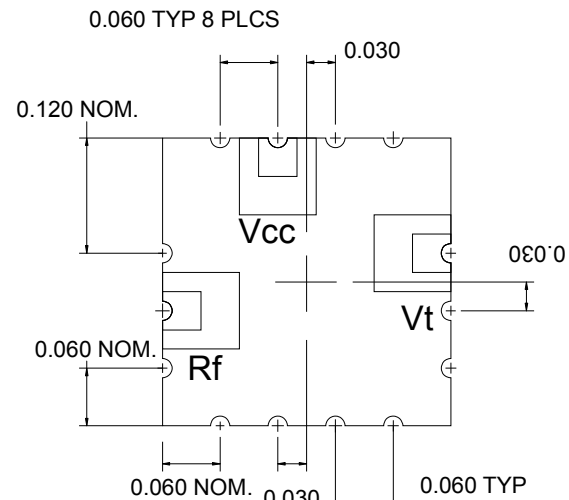

- Notes:
1. The case is ground.
 2. Soldermask/pad layout may vary depending on model, consult factory.
 3. Unless otherwise specified all dimensions are in inches.

Part labeling
 Part number: AA=Alpha pre-fix, product family or custom part designator.
 NNN=Numeric 3 to 4 digit specific part number
 Part type: 2 to 4 alpha part type designator
 Date code: MM=month, DD=day, YY=year
 Label material is high temp. polyester film, opaque white, with black marking.

Solder mask/pad details see note 2

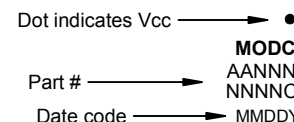
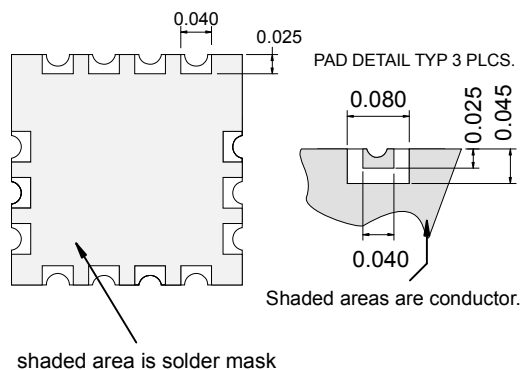

B	Revised to show new label w/ Vcc at top.	
A	Released	
Revision History		
DATE:	8/27/09	MODCO, INC. 806 PACKER WAY SPARKS NV 89431 TEL: (775) 331-2442 FAX: (775) 331-6266
BY:	D. Johnson	
CHECKED:		
REV:	B	
DRAWING #:	CR_SPEC_B.mkd	TITLE: CR PACKAGE OUTLINE

1

2

3

4